

# **Solar container battery mwh meaning**





## Overview

---

MWh is a unit of energy, representing the cumulative product of power and time.  $1 \text{ MWh} = 1,000 \text{ kWh}$  (i.e., 1,000 kilowatt-hours). The MWh value of a system reflects its total energy storage capacity. Example: A 2 MWh battery can store 2,000 kWh of energy. If discharged at 1 MW, it. In the context of a Battery Energy Storage System (BESS), MW (megawatts) and MWh (megawatt-hours) are two crucial specifications that describe different aspects of the system's performance. Understanding the difference between these two units is key to comprehending the capabilities and limitations. In the energy storage sector, MW (megawatts) and MWh (megawatt-hours) are core metrics for describing system capabilities, yet confusion persists regarding their distinctions and applications. This article delves into their differences from perspectives of definition, physical significance.

- MW is a unit of power, indicating the rate of energy conversion.  $1 \text{ MW} = 1000 \text{ kW}$  (Kilowatts). The power level determines how much energy storage system can release or absorb per unit time, directly affecting its peak and frequency regulation capabilities. For example, a 100MW/200MWh energy storage. We combine high energy density batteries, power conversion and control systems in an upgraded shipping container package. Lithium batteries are CATL brand, whose LFP chemistry packs 1 MWh of energy into a battery volume of 2.88 m<sup>3</sup> weighing 5,960 kg. Our design incorporates safety protection.

In the context of a Battery Energy Storage System (BESS), MW (megawatts) and MWh (megawatt-hours) are two crucial specifications that describe different aspects of the system's performance. Understanding the difference between these two units is key to comprehending the capabilities and limitations. Unlike solar farms that use a single unit (like MW), battery storage platforms use MW and MWh together – a combo that confuses even seasoned engineers. But here's the kicker: MW measures power, while MWh measures energy capacity. Think of it like a water hose – MW is how fast water flows (power).



## Solar container battery mwh meaning

---



### Understanding MW and MWh in Battery Energy Storage ...

The MW and MWh specifications of a BESS are both important, but they serve different purposes. The MW rating determines how much power the system can deliver at any moment, while ...

### Sungrow PowerTitan 3.0 BESS reaches 6.9 MWh in 20-ft container

PowerTitan 3.0 delivers 6.9 MWh in a standard 20-ft ISO container, integrating batteries with the string PCS for 2- to 8-hour designs. It features the first mass-produced 661Ah stacking LFP ...



### Energy storage battery mwh meaning

The total installed capacity of energy storage in the US is around 1000 MWh: PHS (Pumped Hydro Storage), CAES (Compressed Air Energy Storage), RFB (Redox Flow Battery), and HFB are on the ...

### Understanding Battery Energy Storage Systems (BESS): The Crucial

Discover the essentials of Battery Energy Storage Systems (BESS) in 2025: Learn the key differences between power (MW) and energy



capacity (MWh), their critical interplay, real-world ...



### Distinguishing MW from MWh in Energy Storage Systems

2. MWh (Megawatt-hour) - The "Endurance" of Energy Storage Systems MWh is a unit of energy, representing the cumulative product of power and time. 1 MWh = ...

### What does MWh mean for energy storage system

In the context of a Battery Energy Storage System (BESS), MW (megawatts) and MWh (megawatt-hours) are two crucial specifications that describe different aspects of the system's performance. ...



### Demystifying Energy Storage: What Does 1MWh Battery Really Mean?

Picture this: A 40-foot shipping container humming behind a shopping mall, storing enough energy to power 700 refrigerators simultaneously during peak hours. That's your 1MWh battery in action.



## Distinguishing MW from MWh in Energy Storage Systems

2. MWh (Megawatt-hour) - The "Endurance" of Energy Storage Systems MWh is a unit of energy, representing the cumulative product of power and time. 1 MWh = 1,000 kWh (i.e., 1,000 kilowatt ...



Application scenarios of energy storage battery products

## Demystifying Power Storage Platform Units: MW vs. MWh Explained

You're not alone! Unlike solar farms that use a single unit (like MW), battery storage platforms use MW and MWh together - a combo that confuses even seasoned engineers. But here's ...

## RatedPower -- Smart flow for energy

S\*N KFP;KE DN6=DNC8KN K7= EQK DCG=>EK Q  
DE6 KGE: NGE6E8D KN8K D\*EK@3/3K6=G(ED2  
0ML.,1+B,B9)L)'BL'% "H.#L!%!)B,L.9L 1-AB!. 9  
LD\*EK NG DK DE ...

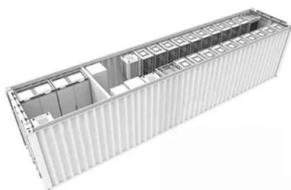
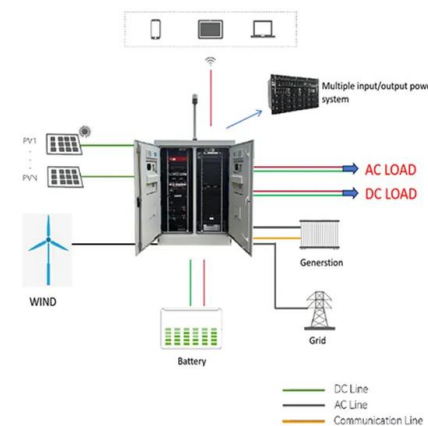

## Distinguishing MW from MWh in Energy Storage Systems

Energy storage projects are often labeled in the format "XX MW/XX MWh" (e.g., 100 MW/200 MWh or 125 kW/261 kWh for modular cabinet systems). The ratio of capacity to power (e.g., 200 MWh ÷ 100 ...



## What are MW and MWh in renewable energy?

At first glance, these units may seem confusing to those unfamiliar with the energy industry. So, what do they actually mean? How are MW and MWh different? And how do they work ...



## CATL EnerC+ 306 4MWH Battery Energy Storage ...

The EnerC+ container is a modular integrated product with rechargeable lithium-ion batteries. It offers high energy density, long service life, and efficient energy ...

## Contact Us

---

For catalog requests, pricing, or partnerships, please visit:  
<https://www.crossworldtours.co.za>